

# Toshiba Industrial Printer and Panther Shadow Print & Apply System

- > Low Volume Print and Apply System
- > Toshiba BEX4T1 or BEX4T2 Industrial Printers
- > Prints and applies label up to 4.7" x 8"
- > Applies 10-40 labels per minute\*
- > 800 meter/2,624' - 8"OD Ribbon (BEX4T1)
- > Stand-alone or automated production integration



## STANDARD FEATURES



### Printer

- Rugged Industrial printer series
- BEX4T1 or BEX4T2 Printer
- Thermal Transfer or Direct Thermal Printers
- Resolution in 200 or 300 DPI
- Maximum Print Speed
  - 14 IPS (BEX4T1)
  - 12 IPS (BEX4T2)
- Large Ribbon Capacity
  - 800 meter (BEX4T1)
  - 600 meter (BEX4T2)

- Long head life warranty
  - 3 million linear inches
- Programming Language
  - TPCL (Toshiba), ZPL (Zebra)
- Printer Communication Interface
  - USB and Ethernet

### Applicator

- 13" Stroke (Peel/Home to Base +13")
- Auto – Tamp Product Contact Sensing
- Print Request Push Button
- Table Top Mount

### Top Apply-Optional Stand



### Side Apply-Optional Stand

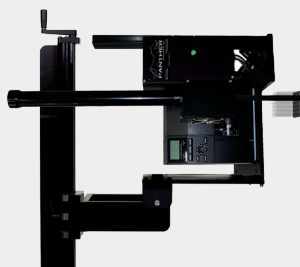

Models	PASHADOWT1	PASHADOWT2
<b>Printer Specification</b>		
Printer Model	BEX4T1GS12DM01	BEX4T2GS12M01
Head Type	Near Edge	Flat
Technology	Thermal Transfer/Direct Thermal	Thermal Transfer/Direct Thermal
Resolution	203 or 305 DPI	200 or 300 DPI
Print Speed	14 IPS	12 IPS
Print Width (Max)	4.09"	4.09"
<b>Media</b>		
Ribbon Length (Max)	800M (2,624')	600M (1,968')
Ribbon Core Diameter	1"	1"
Ribbon Outer Diameter (OD)	3.45"	3.45"
Ribbon Type	CSO	CSO
Label Width (Min-Max)	.98" – 4.72"	.98" – 4.72"
Label Length (Min-Max)	2" – 8"	2" – 8"
Label Core Diameter	3"	3"
Label Outer Diameter (OD)	8" Roll	8" Roll
Label Type	Non-Perforated	Non-Perforated
<b>Printer Communication (std)</b>	USB, Ethernet	USB, Ethernet
<b>Printer Communication (opt)</b>	USB, Ethernet, Serial	USB, Ethernet, Serial
	USB, Ethernet, Parallel	USB, Ethernet, Parallel
	USB, Ethernet, Wireless (802.11 b/g)	USB, Ethernet, Wireless (802.11 b/g)
	RFID, Ribbon Save	
Options		
<b>Printer Environment</b>		
Operating Temperature	40 °- 104° F (5° to 40°C)	40 °- 104° F (5° to 40°C)
Humidity	25-85% RH (Non-Condensing)	25-85% RH (Non-Condensing)
<b>Shadow Applicator (standard)</b>		
Type	Electric – No Compressed Air	Electric – No Compressed Air
Stroke	13" (Peel/Home to Base +13")	13" (Peel/Home to Base +13")
Tamp	Auto-Tamp Product Contact Sensing	Auto-Tamp Product Contact Sensing
	Print Request Push Button	Print Request Push Button
Power	Electrical 115-240 VAC, 50/60 Hz at 5A max (No Air Required)	Electrical 115-240 VAC, 50/60 Hz at 5A max (No Air Required)
Configuration	Table - Top	Table - Top
<b>Applicator (optional)</b>		
	Stand Mount – Side Apply	Stand Mount – Side Apply
	Stand Mount – Top Apply	Stand Mount – Top Apply
	Palm Switch	Palm Switch
	Foot Switch	Foot Switch
<b>Applicator Shipping Weight</b>	97 LBS	97 LBS

## SPECIFICATIONS

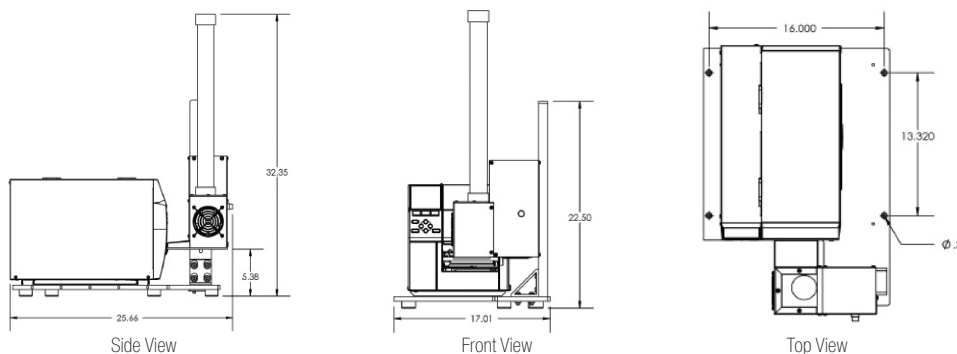

Scan for more info

\*Varies depending on label length, printer speed, and height of the product labeled.